

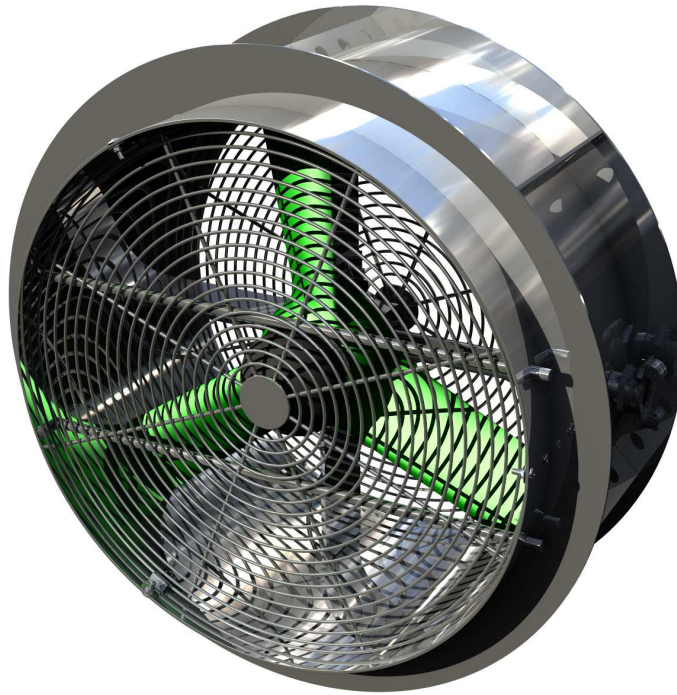

CLARK TYPHOON 500mm STEEL FAN

Product Data Sheet – 18AF043



CLARK TYPHOON 500mm STEEL FAN

The Clark Typhoon 500mm steel pneumatic air fan is a rugged air fan for use in underground coal mines, hard rock mines and construction sites. The fan can be used for ventilation purposes to either draw polluted air or gases away from an area or to ventilate with clean air.

The outer housing is constructed from Zinc coated mild steel. The drive hub and guards are of a steel construction. The three blade impeller is made from FRAS polyurethane and has a unique double function of allowing the air supply to turn the blades, meaning that there is no actual motor, and it also creates the air flow of the fan.

The fan can be used as a stand alone unit or with ducting fitted over the outer housing. Two hanging points are provided so that the fan can easily be mounted with chain or straps from a roof.

The air inlet is a standard Type A snap coupling style. For a light weight alternative for use in hazardous zones use the Clark Typhoon 500mm FRAS fibreglass fan 18AF041

Features:

- Steel cowling
- Rugged construction
- 3 blade impeller
- Variable speed

Applications:

- Hard rock mines
- Coal mines
- Tunnels and shafts
- Sewers and manholes
- Refineries
- Tanks and ship's holds



*Designers and
manufacturers of
mining and construction
equipment*

A.B.N. 42 050 287 173 | A.C.N. 050 287 173

SALES

ph. 612 4272 8311
fx. 612 4272 8533
30 Waverley Drive
Unanderra NSW 2526
cmsadmin@bigpond.com

ACCOUNTS

ph. 612 4271 4036
fx. 612 4271 4015
30 Waverley Drive
Unanderra NSW 2526
clarksminingaccounts@bigpond.com

www.clarksmineingservices.com.au

[g00.gl/q0oy4K](https://www.youtube.com/watch?v=q0oy4K)



CLARK TYPHOON 500mm STEEL FAN

Product Data Sheet

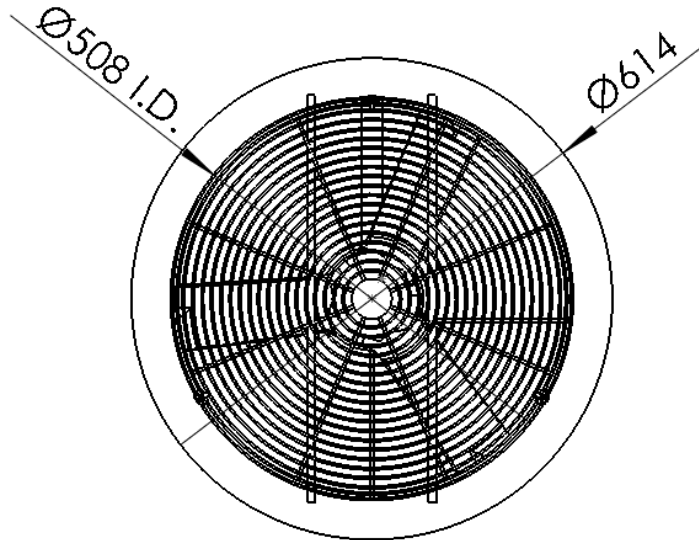
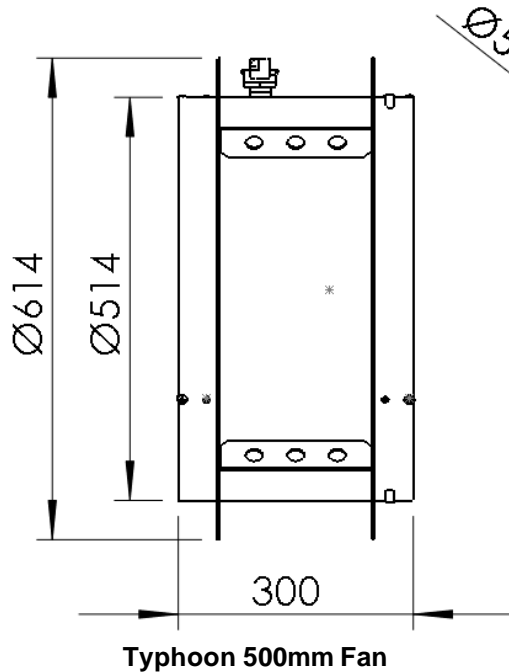

Specifications:

- ⊗ Weight: 27kg
- ⊗ Overall length: 300 mm
- ⊗ Internal diameter: 508mm
- ⊗ External diameter ends: 514 mm
- ⊗ External diameter flange: 614mm
- ⊗ Impeller: 500 mm
- ⊗ Air consumption: 0.07 m³/sec
- ⊗ Fan discharge @ 650kpa: 2.4 m³/sec

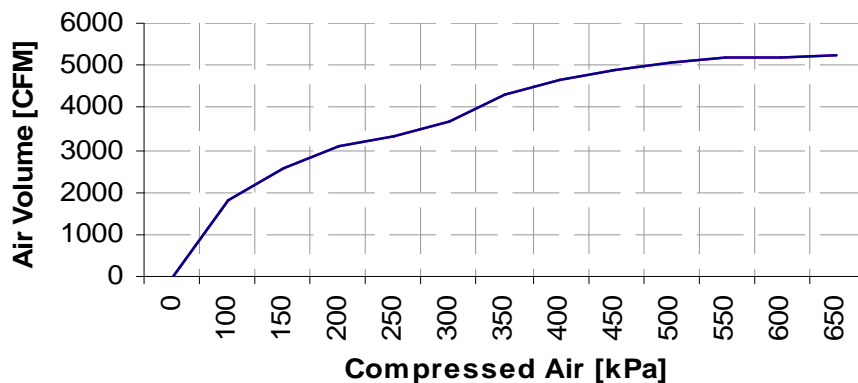
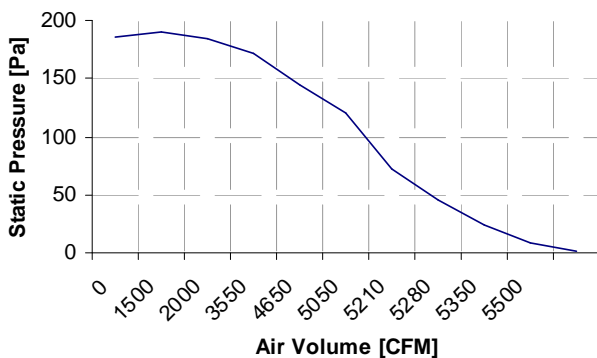

Designers and manufacturers of mining and construction equipment

A.B.N. 42 050 287 173 | A.C.N. 050 287 173

SALES

ph. 612 4272 8311
 fx. 612 4272 8533
 30 Waverley Drive
 Unanderra NSW 2526
 cmsadmin@bigpond.com

ACCOUNTS

ph. 612 4271 4036
 fx. 612 4271 4015
 30 Waverley Drive
 Unanderra NSW 2526
 clarksmineaccounts@bigpond.com