



CLARK AF250 PNEUMATIC FAN

Product Data Sheet



CLARK AF250 FAN

The Clark AF250 pneumatic air fan is a small, high output air fan for use in underground coal mines, hard rock mines and construction sites. The fan can be used for ventilation purposes to either draw polluted air or gases away from an area or to ventilate with clean air.

The outer housing, guards and motor of the AF250 are of a steel construction. The eight blade impeller is made from Anti Static Glass Reinforced Polyamide (PAGAS) material which is suitable for explosive environments.

The fan can be used as a stand alone unit or with ducting fitted over the outer housing. Two hanging points are provided so that the fan can easily be mounted with chain or straps from a roof.

The air inlet is a standard Type A snap coupling style and the air stream requires light lubrication as detailed on the specifications layout page.

Features:

- Steel cowling
- Air Motor powered
- 8 blade impeller
- Variable speed
- Fixed pitch blades

Specifications:

- Air delivery 0.6m³/sec at 600kPa
- Air consumption – 26 l/sec
- Weight 9kg
- Fan blade Ø250mm
- Housing O.D. Ø265mm
- 73 db max
- -20° to +80°c operating range



*Designers and
manufacturers of
mining and construction
equipment*

A.B.N. 42 050 287 173 | A.C.N. 050 287 173

SALES

ph. 612 4272 8311
fx. 612 4272 8533
30 Waverley Drive
Unanderra NSW 2526
cmsadmin@bigpond.com

ACCOUNTS

ph. 612 4271 4036
fx. 612 4271 4015
30 Waverley Drive
Unanderra NSW 2526
clarksmineaccounts@bigpond.com

www.clarksmineingservices.com.au

[g00.g1/q0oy4K](https://www.youtube.com/watch?v=q0oy4K)



CLARK AF250 PNEUMATIC FAN

Product Data Sheet

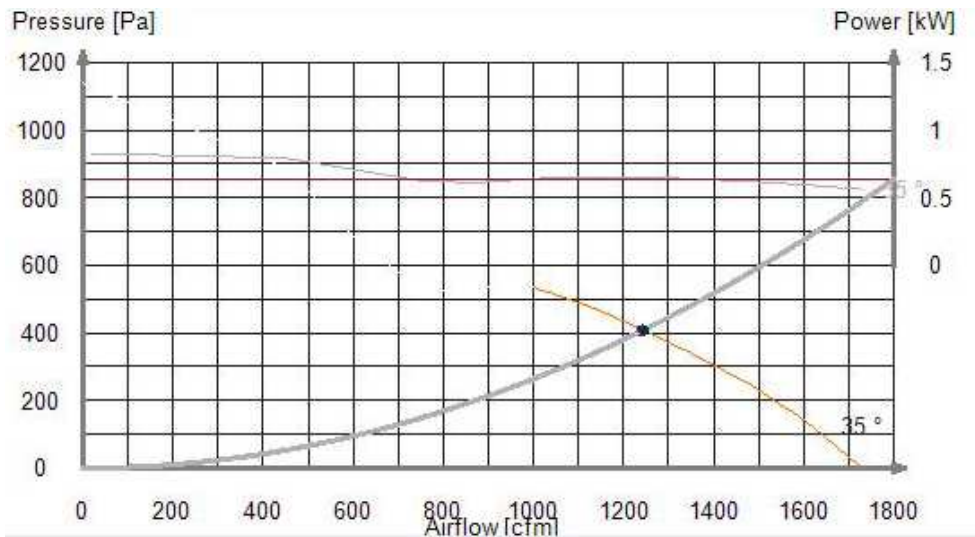
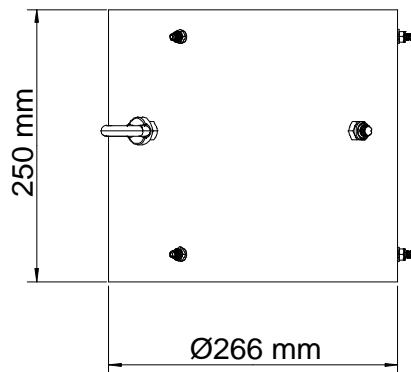
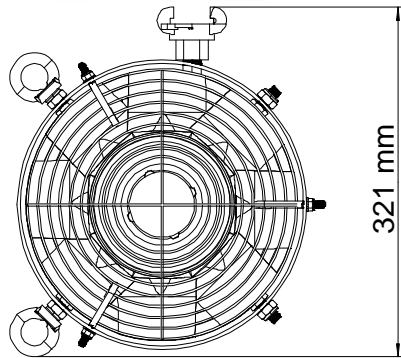

Air filtration and lubrication:

Use a 64 micron filter.

Drop rate of 4-5 drops/min continuous operation

Drop rate of 9-12 drops/min intermittent operation



*Designers and
manufacturers of
mining and construction
equipment*

A.B.N. 42 050 287 173 | A.C.N. 050 287 173

SALES

ph. 612 4272 8311
fx. 612 4272 8533
30 Waverley Drive
Unanderra NSW 2526
cmsadmin@bigpond.com

ACCOUNTS

ph. 612 4271 4036
fx. 612 4271 4015
30 Waverley Drive
Unanderra NSW 2526
clarksmineaccounts@bigpond.com