

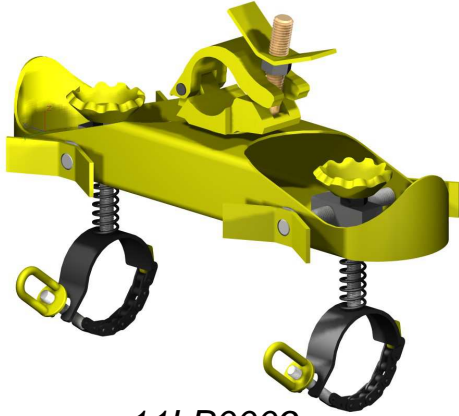

CLARK LASER FRAMES AND HANGERS

Product Data Sheet



11LB0009
LD60 Laser Frame

- Hangers and frames for survey lasers
- Suitable for underground coal
- Suitable for civil tunnels
- Suitable for industrial applications
- Heavy duty
- Easy adjustment of laser angles

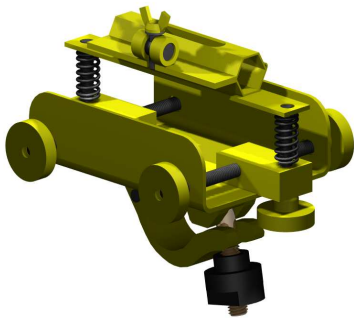

11 LF 01M
Mini Laser Frame

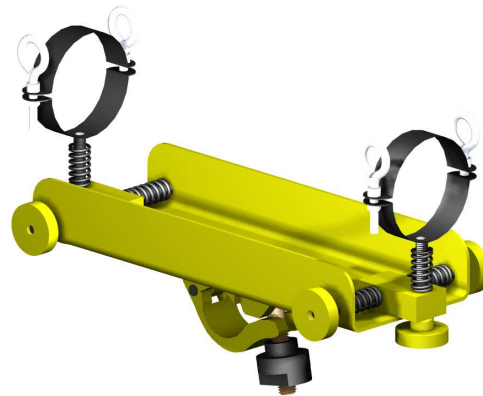

11 LF 01
Laser Frame

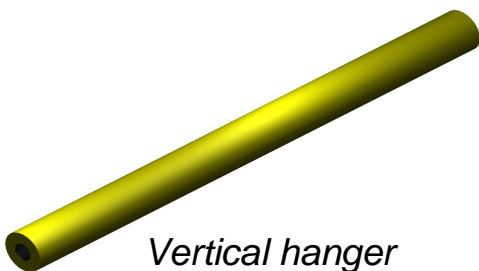

Vertical hanger
(11 LF 02 shown)

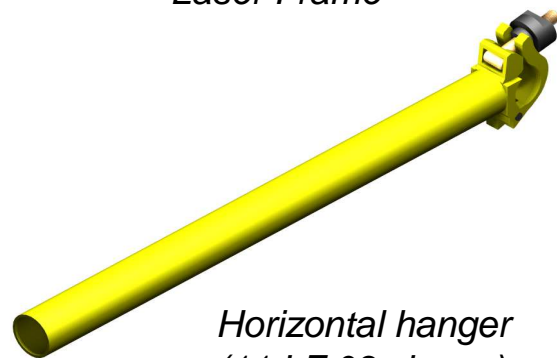

Horizontal hanger
(11 LF 03 shown)



*Designers and
manufacturers of
mining and construction
equipment*

A.B.N. 42 050 287 173 | A.C.N. 050 287 173

SALES

ph. 612 4272 8311
fx. 612 4272 8533
30 Waverley Drive
Unanderra NSW 2526
cmsadmin@bigpond.com

ACCOUNTS

ph. 612 4271 4036
fx. 612 4271 4015
30 Waverley Drive
Unanderra NSW 2526
clarksmineaccounts@bigpond.com

www.clarksmineingservices.com.au

[g00.gl/q0oy4K](https://www.youtube.com/watch?v=q0oy4K)



CLARK LASER FRAMES AND HANGERS

Product Data Sheet

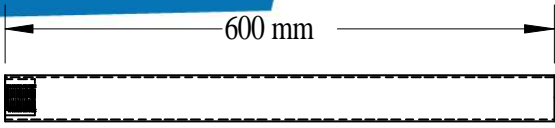

11 LF 02 Vertical hanger 600 long

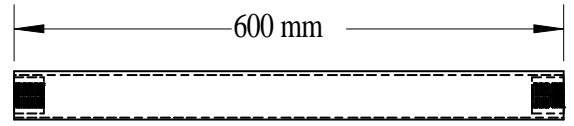
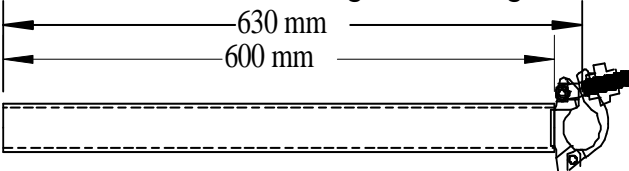

11 LF 02b Vertical hanger 600 long

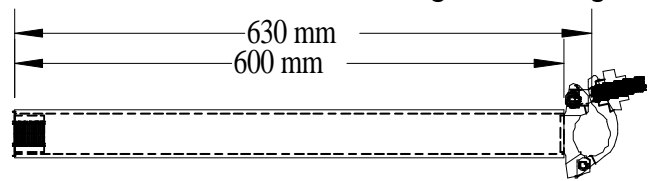

11 LF 03 Horizontal hanger 600 long

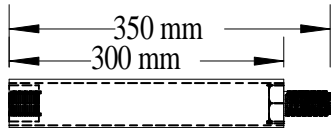

11 LF 04 Horizontal hanger 600 long

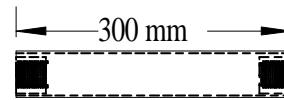

11 LF 05 Extension hanger 300 long

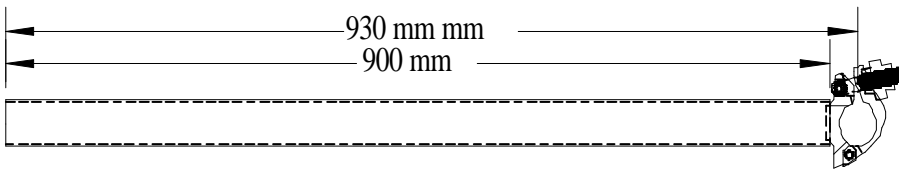

11 LF 05a Extension hanger 300 long

11 LF 06 Horizontal hanger 900 long

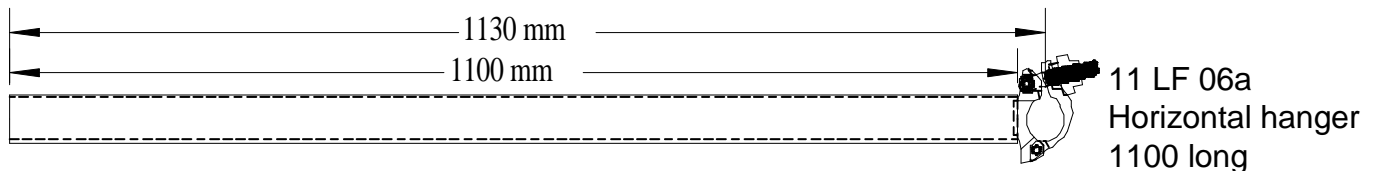

11 LF 06a Horizontal hanger 1100 long

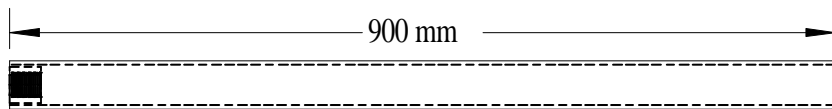

11 LF 07 Vertical hanger 900 long

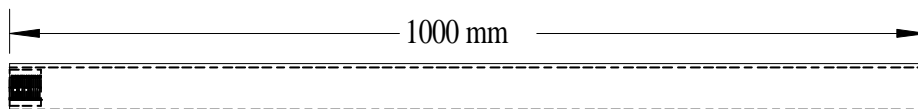

11 LF 07a Vertical hanger 1000 long

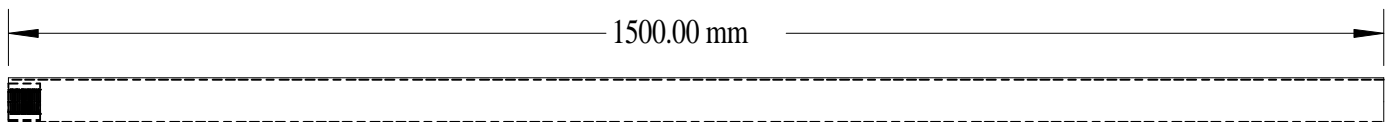

11 LF 07b Vertical hanger 1500 long



Designers and manufacturers of mining and construction equipment

A.B.N. 42 050 287 173 | A.C.N. 050 287 173

SALES

ph. 612 4272 8311
fx. 612 4272 8533
30 Waverley Drive
Unanderra NSW 2526
cmsadmin@bigpond.com

ACCOUNTS

ph. 612 4271 4036
fx. 612 4271 4015
30 Waverley Drive
Unanderra NSW 2526
clarksmineaccounts@bigpond.com

www.clarksmine.com.au

[goo.gl/q0oy4K](https://www.youtube.com/watch?v=q0oy4K)